

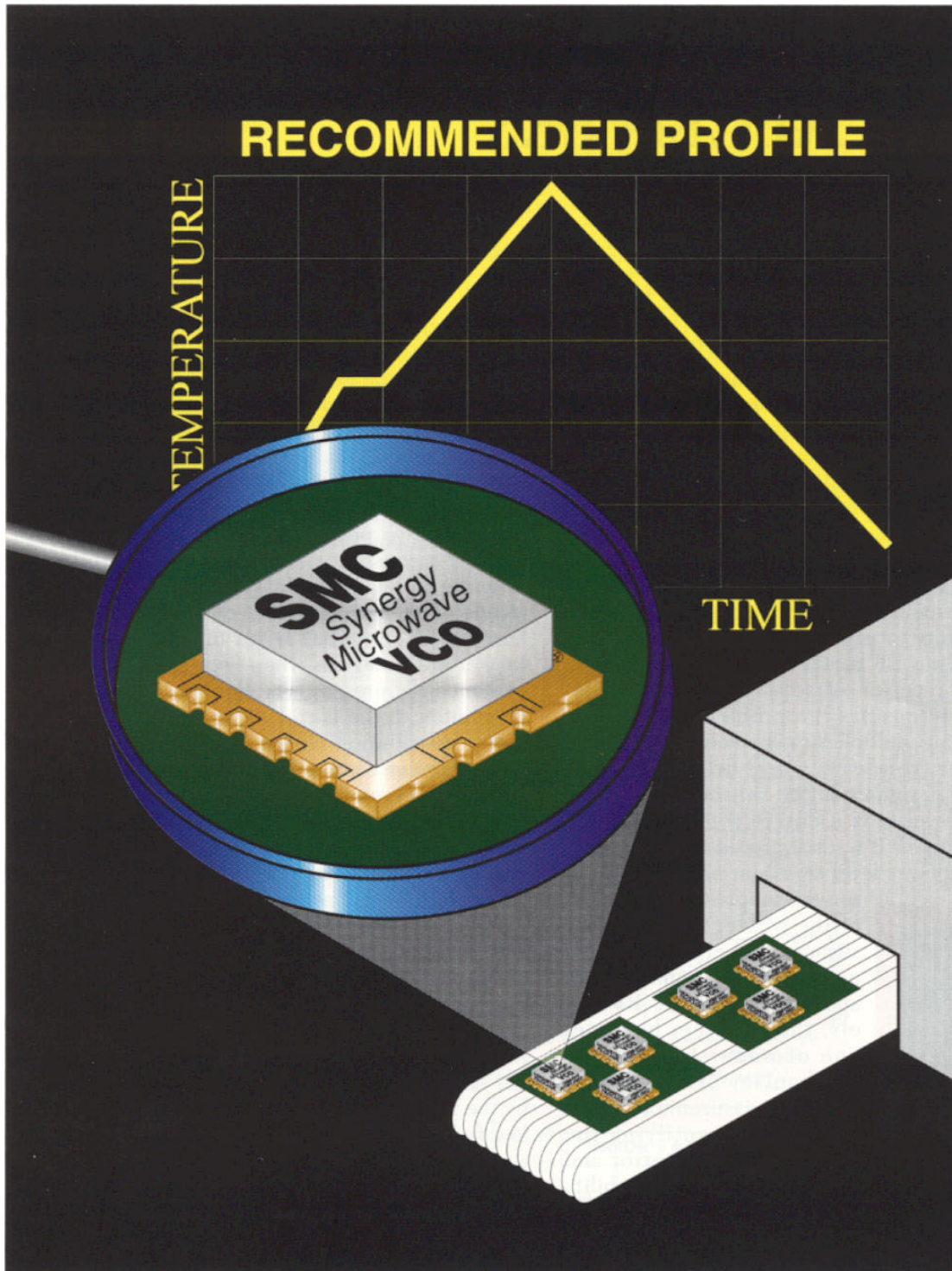

# microwave JOURNAL®

SEPTEMBER 1995  
VOL. 38, NO. 9



## **ELECTRONIC DEFENSE**

**SIMULTANEOUS  
SIGNAL ERRORS  
IN WIDEBAND  
IFM RECEIVERS**

**WIDE, WIDER,  
WIDEST**

**SYNTHETIC  
APERTURE  
ANTENNAS**

CONTENTS, p. 10

horizon  house

## TECHNICAL FEATURE

# SIMULTANEOUS SIGNAL ERRORS IN WIDEBAND IFM RECEIVERS

The wide bandwidth instantaneous frequency measurement (IFM) receiver offers the system designer high probability of intercept over wide instantaneous RF bandwidths and high dynamic ranges. Receivers that simultaneously process the full 2 to 18 GHz RF band, providing digital RF frequency, RF amplitude, pulse width and other parametric data over a 70 dB dynamic range, are currently in production. The digital frequency discriminator (DFD) is the frequency measurement component of the IFM receiver. The ability to process economically wide instantaneous RF bandwidths, while making this type of receiver attractive to the system designer, intensifies the problem of correctly processing multiple simultaneous signals.

In the trivial case, where two simultaneous RF input signals differ substantially in RF power level, it is useful to consider that the IFM receiver is a serial processor of the highest RF power level signal instantaneously observed, suppressing the effect of the weaker signal. In the situation where the two simultaneous RF signals are of approximately equal RF levels, the problem becomes one of understanding the mechanism by which frequency measurement errors are made, quantifying the magnitude of this error and determining the probability of detection of the presence of this error.

Fig. 1. A miniature DFD for airborne applications.



The basic frequency measurement mechanism consists of a multicorrelator DFD, where an RF limiting amplifier is employed to drive a power limited RF signal to a parallel array of microwave correlators. Subsequent video and digital processing is employed to extract the measured RF frequency digital data. *Figure 1* shows a miniature DFD for a typical airborne application.

The RF input to the DFD is first amplified and then limited by an RF amplifier. This setup serves two purposes. By limiting the RF level to a constant value, the video outputs from the correlators are also stabilized in magnitude. The capture effect of the nonlinear limiting RF amplifier tends to suppress the weaker of two signals when two signals are simultaneously present. The limited RF is then distributed to the correlator array by the RF power distribution circuit. The shown DFD uses a five-correlator array. The actual number of correlators employed in a specific DFD depends on the RF bandwidth, desired frequency measurement accuracy and other factors, one of which is cost. DFDs have been produced with as few as three correlators and as many as 10.

The microwave correlator includes power dividers, an RF delay line and a detector set. The microwave correlator provides the mathematical function of dividing the RF input into two paths, delaying one path with respect to the other then multiplying the delayed signal by the undelayed signal. Considering only the low frequency product of this multiplication, the microwave correlator produces a video output proportional to the phase difference be-

---

WILLIAM B. SULLIVAN  
*Wide Band Systems Inc.*  
*Franklin, NJ*

tween the delayed and undelayed RF signals. This video output appears as the sine and cosine of that phase difference. The delay times in a correlator array are arranged in a binary sequence, such as 1, 2, 4, 8... In a DFD with a seven-correlator array, the sequence is x 1, x 2, x 4, x 8, x 16, x 32 and x 64. **Figure 2** shows the correlator array of the miniature DFD.

The shortest RF delay correlator (x 1) determines the unambiguous bandwidth of the DFD, as the shortest RF delay requires the greatest RF frequency change to complete a 360° phase rotation of the sine and cosine video outputs. Since the delays are arranged in a binary sequence, each successively longer RF delay correlator will exhibit a frequency period (360° phase rotation) that is half of the next adjacent correlator. The longest RF delay correlator determines the frequency accuracy and resolution of the DFD. In a seven-correlator array, this correlator is the x 64 correlator. The correlators located between the longest delay correlator and the shortest delay correlator have the sole function of resolving ambiguities due to the periodic (in frequency) nature of the correlator video output.

Therefore, the correlator array will produce a parallel set of periodic video outputs, which are then processed by a variety of video and logic circuits to produce the desired output digital frequency data word. This discussion has centered on the utilization of correlator arrays that employ a 2:1 delay line ratio. This architecture is used to achieve sufficient redundant data to provide a 45° phase margin. Many other design approaches exist. Each of these designs produce a particular phase margin.

The phase margin of a DFD is an expression of the tolerance of the DFD design to phase errors, usually arising from phase errors in the physical devices, operation at low RF signal-to-noise ratio (SNR) and/or operation in the presence of simultaneous signals. The 45° phase margin implies that any or all correlator video outputs can be randomly in error by  $\pm 45^\circ$  without causing ambiguity errors in the measurement. An ambiguity error occurs when adjacent correlators fail to track within the phase margin. This repeated error has a magnitude that is a multiple of a correlator period. This error type is considered undesirable because it is large in magnitude, repeatable and does not average to zero mean with multiple samples.

A second category of error occurs as a result of phase error on the longest delay line correlator (in a seven-correlator array, this is the x 64 correlator). The phase errors in the other correlators will have no effect unless the phase margin is exceeded, producing an ambiguity error. Errors in the long delay correlator appear directly as output frequency measurement errors. This error has the same source as that of the ambiguity error, that is, the phase linearity of the correlator, low RF SNR and/or the presence of simultaneous signals. This error tends to be smaller and if the error source is a low RF input SNR, it will average to zero mean with multiple samples. If the error is due to correlator phase linearity errors, it can be reduced by a calibration process. If the error is due to simultaneous signals, the magnitude and sense of error are determined by the time delay of the longest delay line and the relative frequencies and power levels of the two RF inputs.

▼ Fig. 2 A DFD functional block diagram.

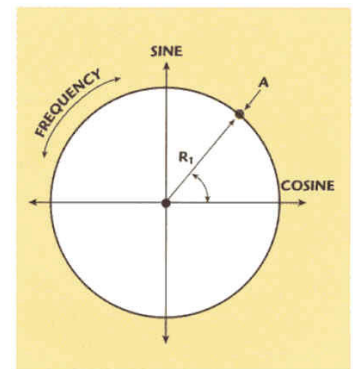
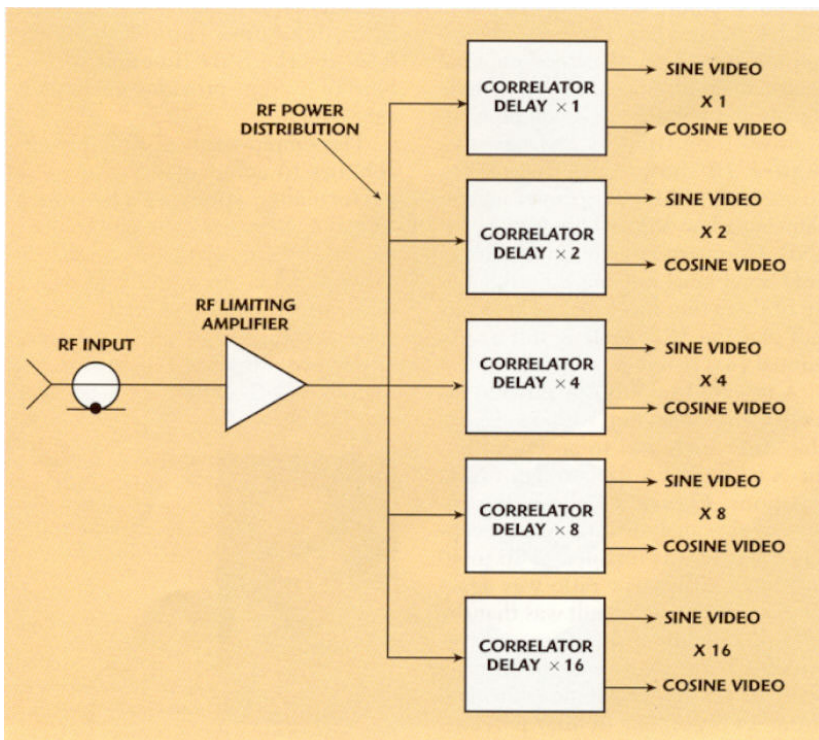

▲ Fig. 3 The correlator video swept signal oscilloscope presentation.

Fig. 4 The correlator video presentation of two signals with 8dB power separation. ▼

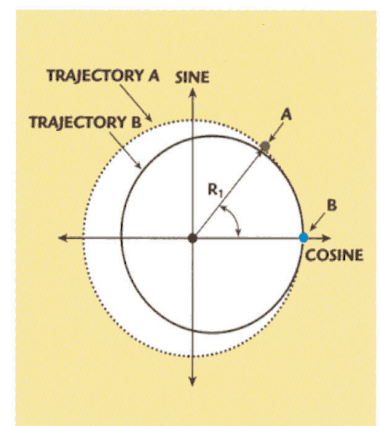

As a basic design objective, it is critical that the DFD design be such that the phase margin is sufficient to assure that ambiguity errors will not occur in any situation (within the defined bandwidth, dynamic range and RF pulse width range) other than a simultaneous signal event. To provide assurance of this operational characteristic, a correlator array is employed with a 2:1 ratio between the delay times of adjacent correlators. This setup provides a phase margin of  $\pm 45^\circ$ , allowing any or all correlator phases to be randomly in error by the  $45^\circ$  without producing an ambiguity error. This capability is provided by a mathematically generated error correction algorithm, processing the signum function of the sine and cosine video signals from the correlator array. While this algorithm is effective in suppressing the effects of minor phase errors, whatever the source, an adverse characteristic is that the errors produced are disproportionate to the errors in the input data when the algorithm is provided with data input that falls outside the available correction region.

The video output of the longest delay line correlator, which can be the  $\times 16$  correlator in a five-correlator array or the  $\times 64$  correlator in a seven-correlator array, is considered. If the correlator sine video output is connected to the vertical input of an oscilloscope and the cosine video output is connected to the horizontal input of the oscilloscope, then the RF input is swept over one or more correlator periods and a circle would be displayed on the oscilloscope. **Figure 3** is an idealized presentation of the expected image. In this ideal case, the angle of the  $R_1$  radial identifies the RF input frequency. The magnitude of the

$R_1$  radial is constant (to the extent that the RF amplifier is an effective limiter, assuming no frequency-dependant losses in the microwave circuits, and assuming a high RF SNR). If the sweep is stopped, the display is that of a single point located at A.

When a second signal is simultaneously combined at the input to the RF amplifier, the oscilloscope display is altered. **Figure 4** presents the approximate display for a simultaneous fixed frequency approximately 8 dB below the swept RF signal. If this fixed-frequency signal was the only RF input, a signal point would be displayed at point B. Trajectory A indicates the location of points on the circle in the presence of the single signal, while trajectory B indicates the new location (and size) of the circle in response to both signals. The previous fixed-frequency example point A is no longer on the solid circle. The effect of simultaneous signals is to alter the size and location of the center of the circle.

Points A and B define the locations of specific sine and cosine video outputs, corresponding to specific RF input frequencies. These frequencies were chosen for graphical convenience in examining simultaneous signal effects on a correlator driven with a limited RF source. In the general case, points A and B are located anywhere on the shown circle.

As the RF power level of the fixed-frequency simultaneous RF input becomes large with respect to the magnitude of the swept RF input, the display will produce successively smaller circles, ultimately converging to the point at B. **Figure 5** provides the approximate display for a simultaneous

fixed frequency that exceeds the power level of the swept frequency by 1 dB.

To predict the frequency measurement error that results from a simultaneous signal event, consider the presentation of **Figure 6**. The situation is an approximation with two signals separated by 2 dB. If the second signal was not present, in response to a particular RF input frequency, a dot would be expected at point A. Adding a second signal, which by itself would produce a dot at point B, changes the trajectory for the swept signal and results in dot A moving to point C. The angular measurement that produced radial  $R_1$  is duplicated by radial  $R_2$ . The effective radial is now  $R_3$ , which locates point C. The error in the video magnitude is the difference between the lengths of radials  $R_1$  and  $R_3$ . The frequency measurement error is the difference in angle between  $R_1$  and  $R_3$ . For this case, theoretically no frequency measurement error occurs when point C moves to a point  $180^\circ$  from point B.

To compare this analysis to measured data, the actual presentation when a single signal is swept over multiple correlator periods is shown in **Figure 7**. The deviation from a circle to a diamond-like shape is due to the operation of the correlator detectors in the linear rather than square law region. The swept data do not exactly overlay, due to frequency-dependent losses in the microwave circuits. The collection of dots at the center is due to the retrace blanking of the sweep generator. **Figure 8** shows the response to a signal fixed-frequency signal. **Figure 9** combines the two

Fig. 5 The correlator video presentation of two signals with  $-1\text{dB}$  power separation. ▼

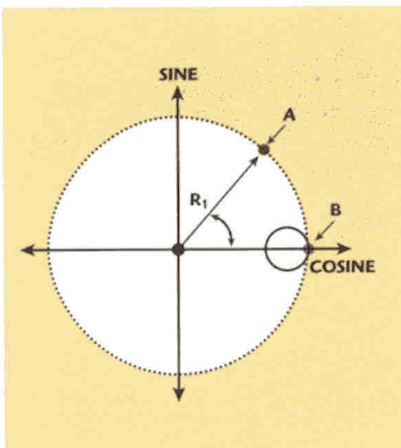

Fig. 6 The correlator video presentation of two signals with 2 dB power separation. ▼

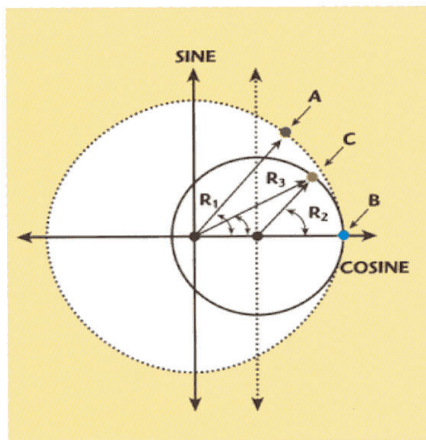
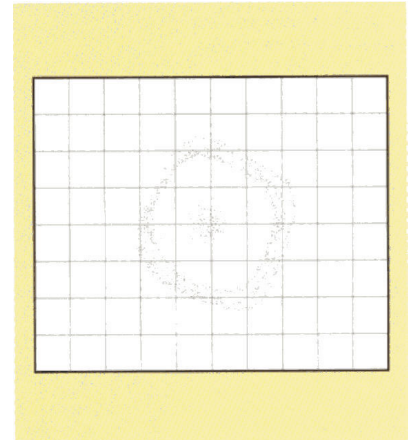

Fig. 7 Measured data of the swept single signal  $\times 64$  correlator. ▼



signals through the limiting RF amplifier, with the fixed signal 3 dB weaker than the swept signal.

In addition to the response of the correlator to a specific set of RF input frequencies being shown, the video signals are indicated. These signals, produced by the correlator in any practical application, deviate substantially from the sine/cosine approximation. One of the major design objectives for DFDs is to make the processing circuits tolerant of substantial variations in the video signals, while continuing to produce accurate digital frequency data.

The displayed data are representative of a larger set of gathered data, representing a sequence of simultaneous signal power ratios. The vertical magnitude scale corresponds to the specific digitization procedure employed in the DFD design. The nominal value of the magnitude is 31.5. Phase error corresponds to a phase quantization of  $5.625^\circ$ , which is the least significant bit (LSB) in the standard DFD design. **Figure 10** plots these data. The thick bar on the center horizontal line is the region where the DFD error exceeds 6 LSB. The horizontal axis is  $\pm$  one period of the x 64 correlator. The vector magnitude is minimum when the two in frequen-

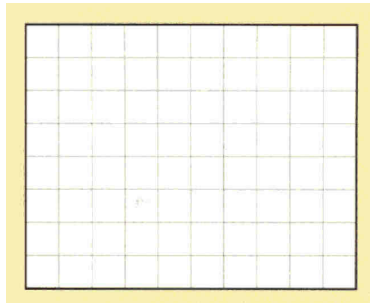

▲ Fig. 8 Measured data of the single fixed-frequency x 64 correlator.

Fig. 9 A swept signal with a fixed simultaneous signal at -3dB ▼

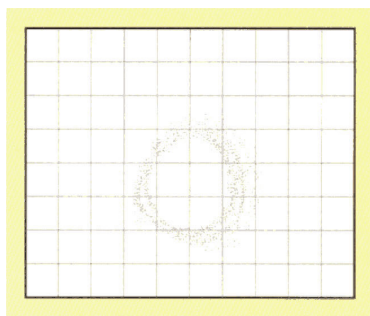

cy by one-half correlator period. When the two simultaneous signals are at the same frequency (even though they are not correlated), no error will result. This result confirms other data and is of interest to the multipath problem. Also, when the two signal frequencies differ by one-half period, there is a narrow region where the frequency measurement error is small.

Fig. 10 The x 64 correlator simultaneous signal error with power ratios of (a) 0, (b) 1, (c) 2, (d) 3, (e) 6 and (f) 10 dB

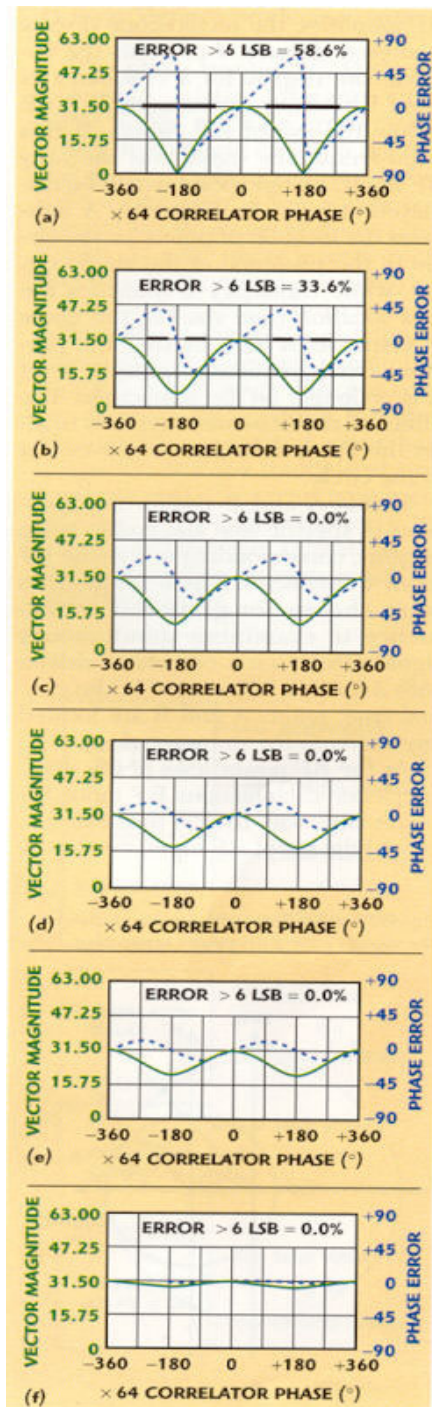

The results of a variety of different RF relative power levels are shown. These data were measured using a seven-correlator 2 to 6 GHz DFD and a five-correlator 0.5 to 2 GHz DFD. The relative RF power levels are at the RF amplifier input, indicating that the compression effects of limiting are included. These data indicate that frequency errors in excess of 6 LSB do not occur when the relative RF power ratio exceeds 2 dB. This result is in agreement with previous experience. The data were taken over a relatively small spread in frequency to minimize the effect of the RF amplifier gain variation. When the RF gain variation is substantial, which is the more common case, the location of the centroid of the narrow region of measurement error in excess of 6 LSB becomes dependent on the specific RF frequencies chosen.

If the allowed limit for frequency measurement errors is  $\pm 6$  LSB, then power differences that exceed  $\pm 1$  dB should not cause errors greater than this limit. There are two modifiers for this comment. Since the gain of the RF limiting amplifier varies with frequency, the absolute location of the center of this  $\pm 1$  dB error region will be frequency dependent. In addition, since each correlator produces the same peak phase error over frequency, frequency combinations exist where the correlator phase error exceeds the error correction algorithm limit, producing an ambiguity error.

**Figure 11** shows the simultaneous signal error of the x 32 correlator, using the phase axis of the x 64 correlator, for a 1 dB power ratio. Comparing the x 32 to x 64 plots, in the positive region of the x 64 correlators phase, the phase errors for these two adjacent correlators are in the same sense. In the negative region of the x 64 correlator phase axis, the phase errors are in opposition. When the relative phase error between the correlators exceeds  $\pm 45^\circ$ , ambiguity errors will result. At approximately the same relative power where noticeable frequency errors occur, substantially larger ambiguity errors are expected.

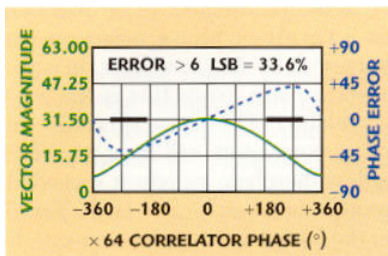

▲ Fig. 11 The x 32 correlator simultaneous signal error with 1 dB power ratio.

Fig. 12 SSD limits on a 1 dB power ratio input. ▼

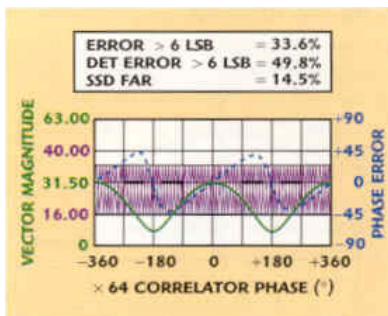
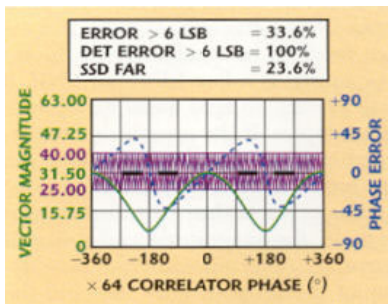

▲ Fig. 13 Low SSD limits on a 1 dB power ratio input.

Fig. 14 A comparison of x 32 and x 64 correlator error patterns. ▼

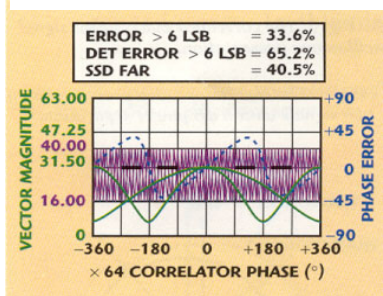

Detection of frequency measurement errors is normally accomplished by detection of the deviation of the vector magnitude from the nominal 31.5 value. To detect this deviation, the square root of the sum of the squared sine and cosine video signals is calculated and compared to a fixed numerical window. For effective operation of this process, the limited RF level from the RF amplifier must be nearly constant and the subsequent microwave circuits must not exhibit frequency-dependent losses. The simultaneous signal detection (SSD)

circuit then defines a window, for example, from a vector magnitude of 25 to a vector magnitude of 40, and flags all measured frequency data outside of this region as of questionable value.

An example of this result is shown in **Figure 12**, where a 1dB power ratio was input and the region for detection of SSD errors is that region out-side of the shaded 25 to 40 region. The resulting probability of an error greater than  $\pm 6$  LSB is predicted to be 33.6 percent. The SSD flag correctly detected 100 percent of the errors greater than  $\pm 6$  LSB. The SSD false alarm rate (FAR), where the SSD flag was set but the error did not exceed  $\pm 6$  LSB, was 23.6 percent. As the detection region is reduced in width, the SSD FAR will increase.

A second problem with the detection of simultaneous signal errors is the effect of diminishing RF SNR on the vector magnitude. For all wide-band, limited RF correlator systems, the mean vector magnitude for a 0 dB RF SNR is one-half the nominal vector magnitude obtained with no noise. The standard deviation of the vector magnitude is dependent on the RF and video bandwidths and the length of the correlator time delay. If the DFD is intended to operate at 0 dB RF SNR, then the SSD region cannot exceed one-half the nominal vector magnitude. Otherwise, single signals at a low RF SNR will be erroneously identified as SSD events. **Figure 13** shows the effect of increasing the SSD acceptance region, allowing a low SSD FAR with low RF SNR. Compared to the more narrow SSD acceptance region, the probability of detection has been reduced by half and the SSD FAR is still a substantial 14.5 percent.

A possible solution to provide effective SSD detection with an acceptable SSD FAR was to accept either the x 64 or the x 32 correlator SSD functions. **Figure 14** shows the results of this analysis. The SSD acceptance region was retained at 16 to 40 and the 1 dB power ratio was again employed. The net result was that the SSD probability of detection only increased from 49.8 percent to 65.2 percent. The SSD FAR almost tripled (from 14.5 percent to 40.5 percent) because the vector magnitude for the x 32 correlator is most likely to indicate an SSD error in the very region where the x 64 correlator is

least likely to make an SSD error.

## CONCLUSION

A properly designed IFM receiver (or DFD) should exhibit a narrow range of sensitivity where multiple simultaneous signals are closely spaced (in relative power). Without the effect of gain variation of the RF limiting amplifier, the error region should not substantially exceed  $\pm 1$  dB. For a constant RF power level difference, as the RF frequencies are varied, the peak vector magnitude error is the same for all correlators. However, because the error phase depends on the correlator delay time, some RF frequency combinations will produce opposite sense phase errors. At these RF frequency/power combinations, the unit is as likely to produce ambiguity errors as the smaller single correlator error.

The effect of gain variation in the RF limiting amplifier is to vary the region of sensitivity to simultaneous signals, in RF power, dependent on the specific RF gains that exist for each of the separate RF inputs. The SSD detection function has the capability to detect errors due to simultaneous signals, but this capability has reduced effect where a low SSD FAR is desired at a low RF SNR. Because the SSD error region is small, the system designer should consider whether the SSD function for this type of system provides any significant benefit.

The employment of multiple correlators to achieve improved SSD performance appears to be unproductive because the SSD FAR increases disproportionately to the improvement in probability of detection. Specifically, the analysis indicates that the use of additional correlators provides SSD indications in regions where errors are least likely to occur. ■



**William B. Sullivan**  
Received his BSEE with honors from San Jose State and his MSEE from Ohio State University. He is founder and president of Wide Band Systems Inc. He was also founder

and president Of Northern Scientific Laboratory. Prior to that, Sullivan was a system engineer for GTE Sylvania, ESL, Probe Systems and Kuras-Alterman Corp.